



te-sa
heating passion

CATALOGUE

VALVOLE E DETENTORI

VALVES AND LOCKSHIELDS

ROBINETS ET TÉS DE RÉGLAGE

КЛАПАНЫ И ЗАПОРНЫЕ ВЕНТИЛИ



VALVOLE MANUALI E DETENTORI

MANUAL VALVES AND LOCKSHIELDS

ROBINETS MANUELS ET TÉS DE RÉGLAGE

РУЧНЫЕ КЛАПАНЫ И ЗАПОРНЫЕ ВЕНТИЛИ





105-04

120-04

ART.
120K



IT Kit manuale ad angolo per tubo rame, plastica o multistrato, senza raccordo, senza autotenuta sul bocchettone. Versione economica.

EN Angle manual kit for copper, plastic or multilayer pipes, without fittings, without self-sealing on the tailpiece. Economical version.

FR Kit manuel équerre pour tube en cuivre, plastique ou multicouche, sans raccord, sans auto-étanchéité sur le raccord. Version économique.

RU Комплект из 2х элементов: угловой ручной клапан + угловой запорный вентиль для медных, пластиковых или многослойных труб, без фитинга, БЕЗ уплотнительного кольца. Экономичная версия.



101-04

122-04

ART.
122K



IT Kit manuale ad angolo per tubo ferro, senza autotenuta sul bocchettone. Versione economica.

EN Angle manual kit for iron pipe, without self-sealing on the tailpiece. Economical version.

FR Kit manuel équerre pour tube en fer, sans auto-étanchéité sur le raccord. Version économique.

RU Комплект из 2х элементов: угловой ручной клапан + угловой запорный вентиль для железной трубы, БЕЗ уплотнительного кольца. Экономичная версия.



101-04

100-04

ART.
100K



IT Kit manuale ad angolo per tubo ferro, senza autotenuta sul bocchettone.

EN Angle manual kit for iron pipe, without self-sealing on the tailpiece.

FR Kit manuel équerre pour tube en fer, sans auto-étanchéité sur le raccord.

RU Комплект из 2х элементов: угловой ручной клапан + угловой запорный вентиль для железной трубы, БЕЗ уплотнительного кольца. Экономичная версия.



ART.
122



IT Valvola manuale ad angolo per tubo ferro, senza autotenuta sul bocchettone. Versione economica.

EN Manual angle valve for iron pipe, without self-sealing on the tailpiece. Economical version.

FR Robinet manuel équerre pour tube en fer, sans auto-étanchéité sur le raccord. Version économique.

RU Угловой ручной клапан для железной трубы, БЕЗ уплотнительного кольца. Экономичная версия.



ART.
101



IT Detentore ad angolo per tubo ferro, senza autotenuta sul bocchettone.

EN Angle lockshield valve for iron pipe, without self-sealing on the tailpiece.

FR Té de réglage équerre pour tubes en fer, sans auto-étanchéité sur le raccord.

RU Угловой запорный вентиль для железной трубы, БЕЗ уплотнительного кольца.



ART.
120



IT Valvola manuale ad angolo per tubo rame, plastica o multistrato, senza raccordo, senza autotenuta sul bocchettone. Versione economica.

EN Manual angle valve for copper, plastic or multilayer pipe, without fitting, without self-sealing on the tailpiece. Economical version.

FR Robinet manuel équerre pour tube en cuivre, plastique ou multicouche, sans raccord, sans auto-étanchéité sur le raccord. Version économique.

RU Угловой ручной клапан для медной, пластиковой или многослойной трубы, без фитинга, БЕЗ уплотнительного кольца. Экономичная версия.

120K-04	1/2"	1	50

122K-04	1/2"	1	50

100K-03	3/8"	1	50
100K-04	1/2"	1	50
100K-05	3/4"	1	20

122-04	1/2"	10	50

101-04	1/2"	10	50

120-04	1/2"	10	50

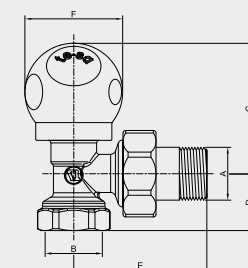

Art.	A	B	C	D	E	F
122-04	1/2"	1/2"	52	22,5	52	Ø39

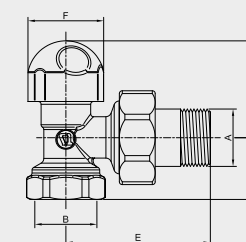

Art.	A	B	C	D	E	F
101-04	1/2"	1/2"	35	22,5	52	Ø27

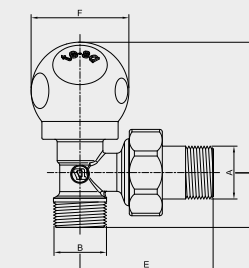

Art.	A	B	C	D	E	F
120-04	1/2"	1/2"	52	22	52	Ø39



ART.
105-04

IT Detentore ad angolo per tubo rame, plastica o multistrato, senza raccordo, senza autotenuta sul bocchettone.

EN Angle lockshield valve for copper, plastic or multilayer pipe, without fitting, without self-sealing on the tailpiece.

FR Té de réglage équerre pour tube en cuivre, plastique ou multicouche, sans raccord, sans auto-étanchéité sur le raccord.

RU Угловой запорный вентиль для медной, пластиковой или многослойной трубы, без фитинга. БЕЗ уплотнительного кольца.



ART.
104S

IT Valvola manuale a doppia squadra per tubo rame, plastica o multistrato, senza raccordo. Reversibile per installazione destra o sinistra. Con autotenuta sul bocchettone.

EN Double angled chrome plated manual valve for copper, plastic or multilayer pipes, without fitting. Reversible for right or left installation. With self-sealing on the tailpiece.

FR Robinet manuel double équerre, pour tube cuivre, plastique et multicouche. Sans Raccord. Réversible pour l'installation droite ou gauche. Avec auto-étanchéité sur le raccord.

RU Двойной угловой хромированный ручной клапан для медной, пластиковой или многослойной трубы, без фитинга. С возможностью установки справа или слева. С уплотнительным кольцом.



ART.
105S

IT Detentore a doppia squadra per tubo rame, plastica o multistrato, senza raccordo. Reversibile per installazione destra o sinistra. Con autotenuta sul bocchettone.

EN Double angled chrome plated lockshield valve for copper, plastic or multilayer pipes, without fitting. Reversible for right or left installation. With self-sealing on the tailpiece.

FR Té de réglage chromé pour tubes cuivre, plastique ou multicouche. Sans raccord. Réversible pour l'installation droite ou gauche. Avec auto-étanchéité sur le raccord.

RU Двойной угловой хромированный запорный вентиль для медной, пластиковой или многослойной трубы, без фитинга. С возможностью установки справа или слева. С уплотнительным кольцом.



102-04



103-04

ART.
102K

IT Kit manuale diritto per tubo ferro, senza autotenuta sul bocchettone.

EN Straight manual kit for iron pipe, without self-sealing on the tailpiece.

FR Kit manuel droit pour tube en fer, sans auto-étanchéité sur le raccord.

RU Комплект из 2х элементов: прямой ручной клапан + прямой запорный вентиль для железной трубы. БЕЗ уплотнительного кольца.



106-04



107-04

ART.
106K

IT Kit manuale diritto per tubo rame, plastica o multistrato, senza raccordo, senza autotenuta sul bocchettone.

EN Straight manual kit for copper, plastic or multilayer pipe, without fitting, without self-sealing on the tailpiece.

FR Kit manuel droit pour tube en cuivre, plastique ou multicouche, sans raccord, sans auto-étanchéité sur le raccord.

RU Комплект из 2х элементов: прямой ручной клапан + прямой запорный вентиль для медной, пластиковой или многослойной трубы, без фитинга. БЕЗ уплотнительного кольца.

105-04	1/2"	1	50

104S-045	1/2"x3/4"E	10	50

105S-045	1/2"x3/4"E	10	50

102K-03	3/8"	1	20
102K-04	1/2"	1	20
102K-05	3/4"	1	20

106K-03	3/8"	1	20
106K-04	1/2"	1	20
106K-045	1/2"x3/4"E	1	20

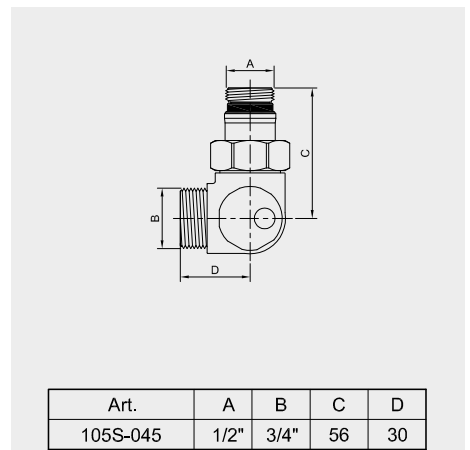
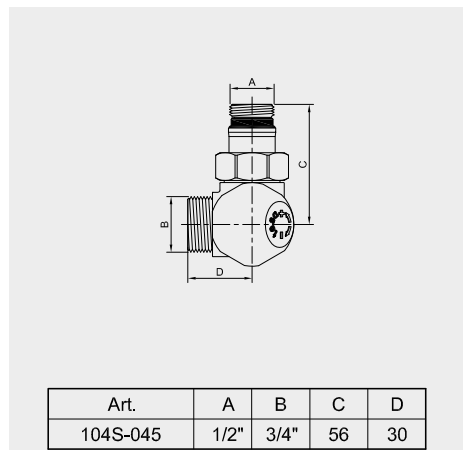
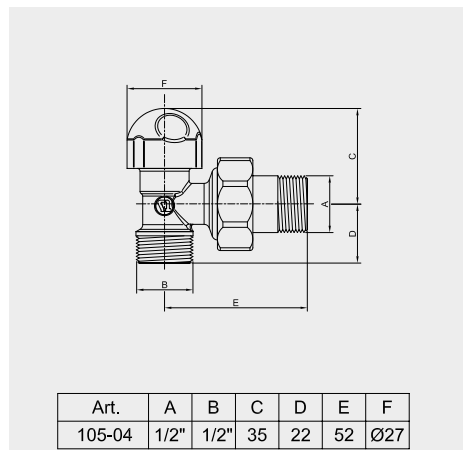



100

ART.
100/1

IT Valvola manuale ad angolo per tubo ferro, con autotenuta sul bocchettone. Art. 100 senza autotenuta sul bocchettone.

EN Manual angle valve for iron pipe, with self-sealing on the tailpiece. Art. 100 without self-sealing on the tailpiece.

FR Robinet manuel équerre pour tube en fer, avec auto-étanchéité sur le raccord. Art. 100 sans auto-étanchéité sur le raccord.

RU Угловой ручной клапан для железной трубы, с уплотнительным кольцом. Art. 100 БЕЗ уплотнительного кольца.

Art.	3/8"	1/2"	3/4"
100/1-03	10	10	10
100/1-04	10	10	10
100/1-05	10	10	10
100-03	10	10	10
100-04	10	10	10
100-05	10	10	10

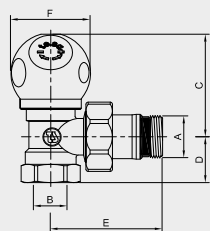

Art.	A	B	C	D	E	F
100/1-03	3/8"	3/8"	49	20	50	Ø39
100/1-04	1/2"	1/2"	49	23	54	Ø39
100/1-05	3/4"	3/4"	49	26	60	Ø39



101

ART.
101/1

IT Detentore ad angolo per tubo ferro, con autotenuta sul bocchettone. Art. 101 senza autotenuta sul bocchettone.

EN Angle lockshield valve for iron pipe, with self-sealing on the tailpiece. Art. 101 without self-sealing on the tailpiece.

FR Té de réglage équerre pour tube fer, avec auto-étanchéité sur le raccord. Art. 101 sans auto-étanchéité sur le raccord.

RU Угловой запорный вентиль для железной трубы, с уплотнительным кольцом. Art. 101 БЕЗ уплотнительного кольца.

Art.	3/8"	1/2"	3/4"
101/1-03	10	10	10
101/1-04	10	10	10
101/1-05	10	10	10
101-03	10	10	10
101-04	10	10	10
101-05	10	10	10

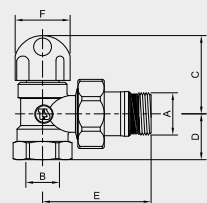

Art.	A	B	C	D	E	F
101/1-03	3/8"	3/8"	39	20	50	Ø27
101/1-04	1/2"	1/2"	39	23	54	Ø27
101/1-05	3/4"	3/4"	39	26	60	Ø27



102

ART.
102/1

IT Valvola manuale diritta per tubo ferro, con autotenuta sul bocchettone. Art. 102 senza autotenuta sul bocchettone.

EN Manual straight valve for iron pipe, with self-sealing on the tailpiece. Art. 102 without self-sealing on the tailpiece.

FR Robinet manuel droit pour tube en fer, avec auto-étanchéité sur le raccord. Art. 102 sans auto-étanchéité sur le raccord.

RU Прямой ручной клапан для железной трубы, с уплотнительным кольцом. Art. 102 БЕЗ уплотнительного кольца.

Art.	3/8"	1/2"	3/4"
102/1-03	10	10	10
102/1-04	10	10	10
102/1-05	10	10	10
102-03	10	10	10
102-04	10	10	10
102-05	10	10	10

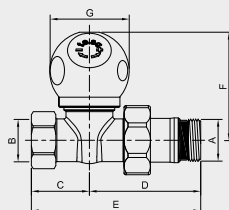

Art.	A	B	C	D	E	F	G
102/1-03	3/8"	3/8"	30	50	80	57	Ø39
102/1-04	1/2"	1/2"	28	54	82	57	Ø39
102/1-05	3/4"	3/4"	28	57	85	57	Ø39



103

ART.
103/1

IT Detentore diritto per tubo ferro, con autotenuta sul bocchettone. Art. 103 senza autotenuta sul bocchettone.

EN Straight lockshield valve for iron pipe, with self-sealing on the tailpiece. Art. 103 without self-sealing on the tailpiece.

FR Té de réglage droit pour tube fer, avec auto-étanchéité sur le raccord. Art. 103 sans auto-étanchéité sur le raccord.

RU Прямой запорный вентиль для железной трубы, с уплотнительным кольцом. Art. 103 БЕЗ уплотнительного кольца.

Art.	3/8"	1/2"	3/4"
103/1-03	10	10	10
103/1-04	10	10	10
103/1-05	10	10	10
103-03	10	10	10
103-04	10	10	10
103-05	10	10	10

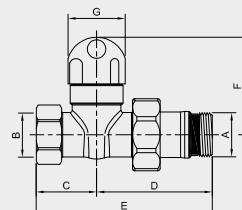

Art.	A	B	C	D	E	F	G
103/1-03	3/8"	3/8"	30	50	80	45	Ø27
103/1-04	1/2"	1/2"	28	54	82	45	Ø27
103/1-05	3/4"	3/4"	28	57	85	45	Ø27



104

ART.
104/1

IT Valvola manuale ad angolo per tubo rame, plastica o multistrato, senza raccordo, con autotenuta sul bocchettone. Art. 104 senza autotenuta sul bocchettone.

EN Manual angle valve for copper, plastic or multilayer pipe, without fitting, with self-sealing on the tailpiece. Art. 104 without self-sealing on the tailpiece.

FR Robinet manuel équerre pour tubes cuivre, plastique ou multicouche sans raccord, avec auto-étanchéité sur le raccord. Art. 104 sans auto-étanchéité sur le raccord.

RU Угловой ручной клапан для медной, пластиковой или многослойной трубы, без фитинга, с уплотнительным кольцом. Art. 104 БЕЗ уплотнительного кольца.

Art.	3/8"	1/2"	3/4"
104/1-03	10	10	10
104/1-04	10	10	10
104/1-045	10	10	10
104-03	10	10	10
104-04	10	10	10
104-045	10	10	10

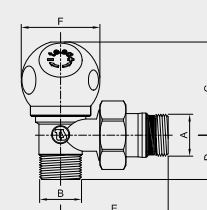

Art.	A	B	C	D	E	F
104/1-03	3/8"	1/2"	49	20	49	Ø39
104/1-04	1/2"	1/2"	49	23	56	Ø39
104/1-045	1/2"	3/4"	49	22	61	Ø39



105

ART.
105/1

IT Detentore ad angolo per tubo rame, plastica o multistrato, senza raccordo, con autotenuta sul bocchettone. Art. 105 senza autotenuta sul bocchettone.

EN Angle lockshield valve for copper, plastic or multilayer pipe, without fitting, with self-sealing on the tailpiece. Art. 105 without self-sealing on the tailpiece.

FR Té de réglage équerre pour tubes cuivre, plastique ou multicouche, sans raccord, avec auto-étanchéité sur le raccord. Art. 105 sans auto-étanchéité sur le raccord.

RU Угловой запорный вентиль для медной, пластиковой или многослойной трубы, без фитинга, с уплотнительным кольцом. Art. 105 БЕЗ уплотнительного кольца.

Art.	3/8"	1/2"	3/4"
105/1-03	10	10	10
105/1-04	10	10	10
105/1-045	10	10	10
105-03	10	10	10
105-04	10	10	10
105-045	10	10	10

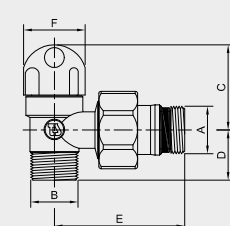

Art.	A	B	C	D	E	F
105/1-03	3/8"	1/2"	41	20	49	Ø27
105/1-04	1/2"	1/2"	41	23	56	Ø27
105/1-045	1/2"	3/4"	41	22	61	Ø27



106



ART.
106/1

IT Valvola manuale diritta per tubo rame, plastica o multistrato, senza raccordo, con autotenuta sul bocchettone. Art. 106 senza autotenuta sul bocchettone.

EN Manual straight valve for copper, plastic or multilayer pipe, without fitting, with self-sealing on the tailpiece. Art. 106 without self-sealing on the tailpiece.

FR Robinet manuel droit pour tubes cuivre, plastique ou multicouche sans raccord, avec auto-étanchéité sur le raccord. Art. 106 sans auto-étanchéité sur le raccord.

RU Прямой ручной клапан для медной, пластиковой или многослойной трубы, без фитинга, с уплотнительным кольцом. Art. 106 БЕЗ уплотнительного кольца.



107



ART.
107/1

IT Detentore diritto per tubo rame, plastica o multistrato, senza raccordo, con autotenuta sul bocchettone. Art. 107 senza autotenuta sul bocchettone.

EN Straight lockshield valve for copper, plastic or multilayer pipe, without fitting, with self-sealing on the tailpiece. Art. 107 without self-sealing on the tailpiece.

FR Té de réglage droit pour tubes cuivre, plastique ou multicouche, sans raccord, avec auto-étanchéité sur le raccord. Art. 107 sans auto-étanchéité sur le raccord.

RU Прямой запорный вентиль для медной, пластиковой или многослойной трубы, без фитинга, с уплотнительным кольцом. Art. 107 БЕЗ уплотнительного кольца.

Art.	3/8"	1/2"	1/2"x3/4"E
106/1-03	3/8"	1/2"	1/2"x3/4"E
106/1-04	3/8"	1/2"	1/2"x3/4"E
106/1-045	3/8"	1/2"	1/2"x3/4"E
106-03	3/8"	1/2"	1/2"x3/4"E
106-04	3/8"	1/2"	1/2"x3/4"E
106-045	3/8"	1/2"	1/2"x3/4"E

Art.	3/8"	1/2"	1/2"x3/4"E
107/1-03	3/8"	1/2"	1/2"x3/4"E
107/1-04	3/8"	1/2"	1/2"x3/4"E
107/1-045	3/8"	1/2"	1/2"x3/4"E
107-03	3/8"	1/2"	1/2"x3/4"E
107-04	3/8"	1/2"	1/2"x3/4"E
107-045	3/8"	1/2"	1/2"x3/4"E

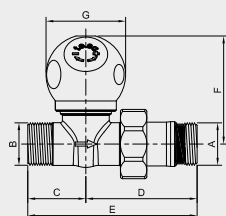

Art.	A	B	C	D	E	F	G
106/1-03	3/8"	1/2"	30	50	80	57	Ø39
106/1-04	1/2"	1/2"	30	53	83	57	Ø39
106/1-045	1/2"	3/4"	28,5	58	86,5	57	Ø39

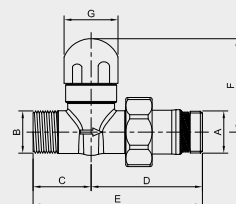

Art.	A	B	C	D	E	F	G
107/1-03	3/8"	1/2"	30	50	80	44	Ø27
107/1-04	1/2"	1/2"	30	53	83	44	Ø27
107/1-045	1/2"	3/4"	29	58	87	44	Ø27

VALVOLE TERMOSTATIZZABILI E DETENTORI
THERMOSTATIZABLE VALVES AND LOCKSHIELDS
ROBINETS THERMOSTATISABLES ET TÉS DE RÉGLAGE
ТЕРМОСТАТИЧЕСКИЕ КЛАПАНЫ И ЗАПОРНЫЕ ВЕНТИЛИ



ART. **110/1KC**

IT Kit termostatico ad angolo per tubo ferro, con autotenuta sul bocchettone.
EN Angle thermostatic kit for iron pipe, with self-sealing on the tailpiece.
FR Kit thermostatisable équerre pour tube en fer, avec auto-étanchéité sur le raccord.
RU Угловой термостатический комплект для железной трубы из 3х элементов. С уплотнительным кольцом.

Art.	Size	Box	Box
110/1KC-03	3/8"	1	20
110/1KC-04	1/2"	1	20



ART. **114/1KC**

IT Kit termostatico ad angolo per tubo rame, plastica o multistrato, con autotenuta sul bocchettone.
EN Angle thermostatic kit for copper, plastic or multilayer pipe, with self-sealing on the tailpiece.
FR Kit thermostatisable équerre pour tube en cuivre, plastique ou multicouche, avec auto-étanchéité sur le raccord.
RU Угловой термостатический комплект для медной, пластиковой или многослойной трубы из 3х элементов. С уплотнительным кольцом.

Art.	Size	Box	Box
114/1KC-03	3/8"	1	20
114/1KC-04	1/2"	1	20



ART. **112/1KC**

IT Kit termostatico diritto per tubo ferro, con autotenuta sul bocchettone.
EN Straight thermostatic kit for iron pipe, with self-sealing on the tailpiece.
FR Kit thermostatisable droit pour tube en fer, avec auto-étanchéité sur le raccord.
RU Прямой термостатический комплект для железной трубы из 3х элементов. С уплотнительным кольцом.

Art.	Size	Box	Box
112/1KC-03	3/8"	1	20
112/1KC-04	1/2"	1	20



ART. **115/1KC**

IT Kit termostatico diritto per tubo rame, plastica o multistrato, con autotenuta sul bocchettone.
EN Straight thermostatic kit for copper, plastic or multilayer pipe, with self-sealing on the tailpiece.
FR Kit thermostatisable droit pour tube en cuivre, plastique ou multicouche, avec auto-étanchéité sur le raccord.
RU Прямой термостатический комплект для медной, пластиковой или многослойной трубы из 3х элементов. С уплотнительным кольцом.

Art.	Size	Box	Box
115/1KC-03	3/8"	1	20
115/1KC-04	1/2"	1	20



ART. **110T/1**

IT Valvola termostattizzabile ad angolo per tubo ferro con manopola, con autotenuta sul bocchettone. Disponibile con cappuccio di protezione (Art. 110C/1).

EN Thermostatizable angle valve for iron pipe with handle, with self-sealing on the tailpiece. Available with protection cap. (Art. 110C/1).

FR Robinet thermostatisable équerre pour tube fer avec poignée, avec auto-étanchéité sur le raccord. Disponible avec capuchon de chantier (Art. 110C/1).

RU Угловой термостатический клапан для железной трубы, с регулировочной ручкой, с уплотнительным кольцом. Возможна поставка с защитным колпачком (Art. 110C/1).

Art.	Size	Box	Box
110T/1-03	3/8"	10	50
110T/1-04	1/2"	10	50
110T/1-05	3/4"	10	50
110T/1-06	1"	5	25
110C/1-03	3/8"	10	50
110C/1-04	1/2"	10	50
110C/1-05	3/4"	10	50
110C/1-06	1"	5	25

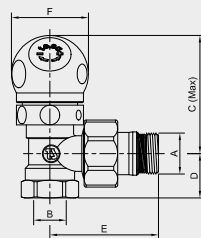

Art.	A	B	C	D	E	F
110T/1-03	3/8"	3/8"	60	20	50	Ø39
110T/1-04	1/2"	1/2"	60	23	54	Ø39
110T/1-05	3/4"	3/4"	60	26	60	Ø39
110T/1-06	1"	1"	63	31	76	Ø39
110C/1-03	3/8"	3/8"	37	20	50	Ø36
110C/1-04	1/2"	1/2"	37	23	54	Ø36
110C/1-05	3/4"	3/4"	37	26	60	Ø36
110C/1-06	1"	1"	40	31	76	Ø36



ART. **101/1**

IT Detentore angolo per tubo ferro, con autotenuta sul bocchettone.

EN Angle lockshield valve for iron pipe, with self-sealing on the tailpiece.

FR Té de réglage équerre pour tube fer avec auto-étanchéité sur le raccord.

RU Угловой запорный вентиль для железной трубы. С уплотнительным кольцом.

Art.	Size	Box	Box
101/1-03	3/8"	10	50
101/1-04	1/2"	10	50
101/1-05	3/4"	10	50
101/1-06	1"	5	25

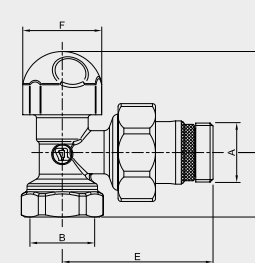

Art.	A	B	C	D	E	F
101/1-03	3/8"	3/8"	39	20	50	Ø27
101/1-04	1/2"	1/2"	39	23	54	Ø27
101/1-05	3/4"	3/4"	39	26	60	Ø27
101/1-06	1"	1"	42	31	76	Ø27



ART. **112T/1**

IT Valvola termostattizzabile diretta per tubo ferro con manopola, con autotenuta sul bocchettone. Disponibile con cappuccio di protezione (Art. 112C/1).

EN Thermostatizable straight valve for iron pipe with handle, with self-sealing on the tailpiece. Available with protection cap (Art. 112C/1).

FR Robinet thermostatisable droit pour tube fer avec poignée, avec auto-étanchéité sur le raccord. Disponible avec capuchon de chantier (Art. 112C/1).

RU Прямой термостатический клапан для железной трубы, с регулировочной ручкой. Возможна поставка с защитным колпачком (Art. 112C/1).

Art.	Size	Box	Box
112T/1-03	3/8"	10	50
112T/1-04	1/2"	10	50
112T/1-05	3/4"	10	50
112T/1-06	1"	5	25
112C/1-03	3/8"	10	50
112C/1-04	1/2"	10	50
112C/1-05	3/4"	10	50
112C/1-06	1"	5	25

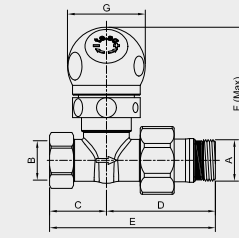

Art.	A	B	C	D	E	F	G
112T/1-03	3/8"	3/8"	30	50	80	69	Ø39
112T/1-04	1/2"	1/2"	28	54	82	69	Ø39
112T/1-05	3/4"	3/4"	28	57	85	69	Ø39
112T/1-06	1"	1"	36	64	100	74	Ø39
112C/1-03	3/8"	3/8"	30	50	80	47	Ø36
112C/1-04	1/2"	1/2"	28	54	82	47	Ø36
112C/1-05	3/4"	3/4"	28	57	85	47	Ø36
112C/1-06	1"	1"	36	64	100	52	Ø36



ART.
103/1

IT Detentore diritto per tubo ferro, con autotenuta sul bocchettone.

EN Straight lockshield valve for iron pipe, with self-sealing on the tailpiece.

FR Té de réglage droit pour tube fer, avec auto-étanchéité sur le raccord.

RU Прямой запорный вентиль для железной трубы. С уплотнительным кольцом.

Art.	3/8"	1/2"	3/4"	1"
103/1-03	3/8"	10	50	
103/1-04	1/2"	10	50	
103/1-05	3/4"	10	50	
103/1-06	1"	5	25	

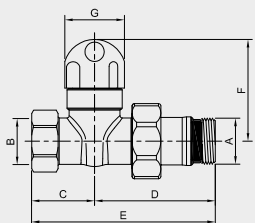

Art.	A	B	C	D	E	F	G
103/1-03	3/8"	3/8"	30	50	80	45	Ø27
103/1-04	1/2"	1/2"	28	54	82	45	Ø27
103/1-05	3/4"	3/4"	28	57	85	45	Ø27
103/1-06	1"	1"	36	64	100	44	Ø27



ART.
114T/1

IT Valvola termostattizzabile ad angolo per tubo rame, plastica o multistrato, con manopola, senza raccordo, con autotenuta sul bocchettone. Disponibile con cappuccio di protezione (Art. 114C/1).

EN Thermostatic angle valve for copper, plastic or multilayer pipe, with handle, without fitting, with self-sealing on the tailpiece. Available with protection cap (Art. 114C/1).

FR Robinet thermostatisable équerre pour tubes cuivre, plastique ou multicouche, avec poignée, sans raccord, avec auto-étanchéité sur le raccord. Disponible avec capuchon de chantier (Art. 114C/1).

RU Угловой термостатический клапан для медной, пластиковой или многослойной трубы, с регулировочной ручкой, с уплотнительным кольцом. Возможна поставка с защитным колпачком (Art. 114C/1).

Art.	3/8"	1/2"	1/2"x3/4"E
114T/1-03	3/8"	10	50
114T/1-04	1/2"	10	50
114T/1-045	1/2"x3/4"E	10	50
114C/1-03	3/8"	10	50
114C/1-04	1/2"	10	50
114C/1-045	1/2"x3/4"E	10	50

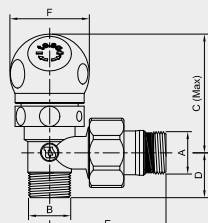

Art.	A	B	C	D	E	F
114T/1-03	3/8"	1/2"	65	20	49	Ø39
114T/1-04	1/2"	1/2"	65	23	56	Ø39
114T/1-045	1/2"	3/4"	65	24	61	Ø39
114C/1-03	3/8"	1/2"	43	20	49	Ø36
114C/1-04	1/2"	1/2"	43	23	56	Ø36
114C/1-045	1/2"	3/4"	43	24	61	Ø36



ART.
105/1

IT Detentore ad angolo per tubo rame, plastica o multistrato, senza raccordo, con autotenuta sul bocchettone.

EN Angle lockshield valve for copper, plastic or multilayer pipe, without fitting, with self-sealing on the tailpiece.

FR Té de réglage équerre pour tubes cuivre, plastique ou multicouche, sans raccord, avec auto-étanchéité sur le raccord.

RU Угловой запорный вентиль для медной, пластиковой или многослойной трубы, без фитинга. С уплотнительным кольцом.

Art.	3/8"	1/2"	1/2"x3/4"E
105/1-03	3/8"	10	50
105/1-04	1/2"	10	50
105/1-045	1/2"x3/4"E	10	50

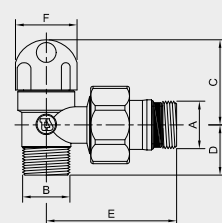

Art.	A	B	C	D	E	F
105/1-03	3/8"	1/2"	41	20	49	Ø27
105/1-04	1/2"	1/2"	41	23	56	Ø27
105/1-045	1/2"	3/4"	41	22	61	Ø27



ART.
115T/1

IT Valvola termostattizzabile diritta per tubo rame, plastica o multistrato, con manopola, senza raccordo, con autotenuta sul bocchettone. Disponibile con cappuccio di protezione (Art. 115C/1).

EN Thermostatic straight valve for copper, plastic or multilayer pipe, with handle, without fitting, with self-sealing on the tailpiece. Available with protection cap (Art. 115C/1).

FR Robinet thermostatisable droit pour tubes cuivre, plastique ou multicouche, avec poignée, sans raccord, avec auto-étanchéité sur le raccord. Disponible avec capuchon de chantier (Art. 115C/1).

RU Прямой термостатический клапан для медной, пластиковой или многослойной трубы, с регулировочной ручкой, с уплотнительным кольцом. Возможна поставка с защитным колпачком (Art. 115C/1).

Art.	3/8"	1/2"	1/2"x3/4"E
115T/1-03	3/8"	10	50
115T/1-04	1/2"	10	50
115T/1-045	1/2"x3/4"E	10	50
115C/1-03	3/8"	10	50
115C/1-04	1/2"	10	50
115C/1-045	1/2"x3/4"E	10	50

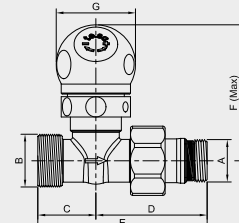

Art.	A	B	C	D	E	F	G
115T/1-03	3/8"	1/2"	30	50	80	68	Ø39
115T/1-04	1/2"	1/2"	30	53	83	68	Ø39
115T/1-045	1/2"	3/4"	29	58	87	68	Ø39
115C/1-03	3/8"	1/2"	30	50	80	46	Ø36
115C/1-04	1/2"	1/2"	30	53	83	46	Ø36
115C/1-045	1/2"	3/4"	29	58	87	46	Ø36



ART.
107/1

IT Detentore diritto per tubo rame, plastica o multistrato, senza raccordo, con autotenuta sul bocchettone.

EN Straight lockshield valve for copper, plastic or multilayer pipe, without fitting, with self-sealing on the tailpiece.

FR Té de réglage droit pour tube cuivre, plastique ou multicouche, sans raccord, avec auto-étanchéité sur le raccord.

RU Прямой запорный вентиль для медной, пластиковой или многослойной трубы, без фитинга. С уплотнительным кольцом.

Art.	3/8"	1/2"	1/2"x3/4"E
107/1-03	3/8"	10	50
107/1-04	1/2"	10	50
107/1-045	1/2"x3/4"E	10	50

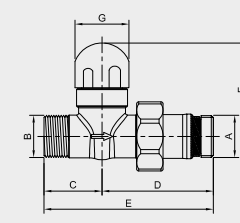

Art.	A	B	C	D	E	F	G
107/1-03	3/8"	1/2"	30	50	80	44	Ø27
107/1-04	1/2"	1/2"	30	53	83	44	Ø27
107/1-045	1/2"	3/4"	29	58	87	44	Ø27



ART.
110DR/1KC

IT Kit termostatico doppia regolazione ad angolo per tubo ferro, con autotenuta sul bocchettone.

EN Double adjustment angle thermostatic kit for iron pipe, with self-sealing on the tailpiece.

FR Kit thermostatique équerre, double réglage, avec connexion pour tube fer.

RU Угловой терmostатический комплект с двойной регулировкой для железной трубы из 3х элементов. С уплотнительным кольцом.

Art.	Size	Unit	Box
110DR/1KC-03	3/8"	1	20
110DR/1KC-04	1/2"	1	20



ART.
112DR/1KC

IT Kit termostatico doppia regolazione diritto per tubo ferro, con autotenuta sul bocchettone.

EN Double adjustment straight thermostatic kit for iron pipe, with self-sealing on the tailpiece.

FR Kit thermostatique droit, double réglage, avec connexion pour tube fer.

RU Прямой терmostатический комплект с двойной регулировкой для железной трубы из 3х элементов. С уплотнительным кольцом.

Art.	Size	Unit	Box
112DR/1KC-03	3/8"	1	20
112DR/1KC-04	1/2"	1	20



ART.
114DR/1KC

IT Kit termostatico doppia regolazione ad angolo per tubo rame, plastica o multistrato, senza raccordi, con autotenuta sul bocchettone.

EN Double adjustment angle thermostatic kit for copper, plastic or multilayer pipe, without fittings, with self-sealing on the tailpiece.

FR Kit thermostatique équerre, double réglage, avec connexion pour tube cuivre, plastique ou multicouche. Sans raccord.

RU Угловой терmostатический комплект с двойной регулировкой для медной, пластиковой или многослойной трубы из 3х элементов, без фитингов. С уплотнительным кольцом.

Art.	Size	Unit	Box
114DR/1KC-03	3/8"	1	20
114DR/1KC-04	1/2"	1	20



ART.
115DR/1KC

IT Kit termostatico doppia regolazione diritto per tubo rame, plastica o multistrato, senza raccordi, con autotenuta sul bocchettone.

EN Double adjustment straight thermostatic kit for copper, plastic or multilayer pipe, without fittings, with self-sealing on the tailpiece.

FR Kit thermostatique droit, double réglage, avec connexion pour tube cuivre, plastique ou multicouche. Sans raccord.

RU Прямой терmostатический комплект с двойной регулировкой для медной, пластиковой или многослойной трубы из 3х элементов, без фитингов. С уплотнительным кольцом.

Art.	Size	Unit	Box
115DR/1KC-03	3/8"	1	20
115DR/1KC-04	1/2"	1	20



ART.
110TDR/1

IT Valvola termostattizzabile ad angolo a doppia regolazione per tubo ferro con manopola, con autotenuta sul bocchettone. Disponibile con cappuccio di protezione (Art. 110CDR/1).

EN Double adjustment thermostattizable angle valve for iron pipe with handle, with self-sealing on the tailpiece. Available with protection cap (Art. 110CDR/1).

FR Robinet thermostatizable équerre double réglage pour tube fer avec poignée, avec auto-étanchéité sur le raccord. Disponible avec capuchon de chantier (Art. 110CDR/1).

RU Угловой терmostатический клапан с двойной регулировкой для железной трубы, с регулировочной ручкой, с уплотнительным кольцом. Возможна поставка с защитным колпачком (Art. 110CDR/1).

Art.	Size	Unit	Box
110TDR/1-03	3/8"	10	50
110TDR/1-04	1/2"	10	50
110TDR/1-05	3/4"	10	50
110CDR/1-03	3/8"	10	50
110CDR/1-04	1/2"	10	50
110CDR/1-05	3/4"	10	50

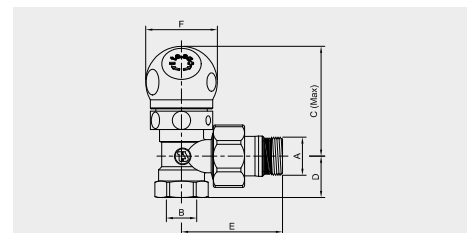

Art.	A	B	C	D	E	F
110TDR/1-03	3/8"	3/8"	60	20	50	Ø39
110TDR/1-04	1/2"	1/2"	60	23	54	Ø39
110TDR/1-05	3/4"	3/4"	60	26	60	Ø39
110CDR/1-03	3/8"	3/8"	37	20	50	Ø36
110CDR/1-04	1/2"	1/2"	37	23	54	Ø36
110CDR/1-05	3/4"	3/4"	37	26	60	Ø36



ART.
112TDR/1

IT Valvola termostattizzabile diretta a doppia regolazione per tubo ferro con manopola, con autotenuta sul bocchettone. Disponibile con cappuccio di protezione (Art. 112CDR/1).

EN Double adjustment thermostattizable straight valve for iron pipe with handle, with self-sealing on the tailpiece. Available with protection cap (Art. 112CDR/1).

FR Robinet thermostatizable droit double réglage pour tube fer avec poignée, avec auto-étanchéité sur le raccord. Disponible avec capuchon de chantier (Art. 112CDR/1).

RU Прямой терmostатический клапан с двойной регулировкой для железной трубы, с регулировочной ручкой, с уплотнительным кольцом. Возможна поставка с защитным колпачком (Art. 112CDR/1).

Art.	Size	Unit	Box
112TDR/1-03	3/8"	10	50
112TDR/1-04	1/2"	10	50
112TDR/1-05	3/4"	10	50
112CDR/1-03	3/8"	10	50
112CDR/1-04	1/2"	10	50
112CDR/1-05	3/4"	10	50

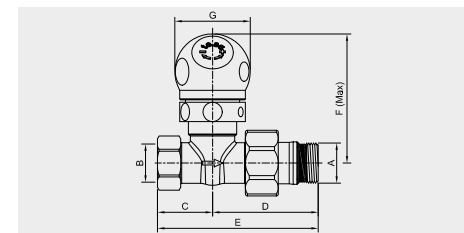

Art.	A	B	C	D	E	F	G
112TDR/1-03	3/8"	3/8"	30	50	80	69	Ø39
112TDR/1-04	1/2"	1/2"	28	54	82	69	Ø39
112TDR/1-05	3/4"	3/4"	28	57	85	69	Ø39
112CDR/1-03	3/8"	3/8"	30	50	80	47	Ø36
112CDR/1-04	1/2"	1/2"	28	54	82	47	Ø36
112CDR/1-05	3/4"	3/4"	28	57	85	47	Ø36



ART.
114TDR/1

IT Valvola termostattizzabile ad angolo a doppia regolazione per tubo rame, plastica o multistrato, con manopola, senza raccordo, con autotenuta sul bocchettone. Disponibile con cappuccio di protezione (Art. 114CDR/1).

EN Double adjustment thermostattizable angle valve for copper, plastic or multilayer pipe, with handle, without fitting, with self-sealing on the tailpiece. Available with protection cap (Art. 114CDR/1).

FR Robinet thermostatizable équerre double réglage pour tubes cuivre, plastique ou multicouche, avec poignée, sans raccord, avec auto-étanchéité sur le raccord. Disponible avec capuchon de chantier (Art. 114CDR/1).

RU Угловой терmostатический клапан с двойной регулировкой для медной, пластиковой или многослойной трубы, с регулировочной ручкой, без фитинга, с уплотнительным кольцом. Возможна поставка с защитным колпачком (Art.114CDR/1).

Art.	Size	Unit	Box
114TDR/1-03	3/8"	10	50
114TDR/1-04	1/2"	10	50
114TDR/1-045	1/2"x3/4"E	10	50
114CDR/1-03	3/8"	10	50
114CDR/1-04	1/2"	10	50
114CDR/1-045	1/2"x3/4"E	10	50

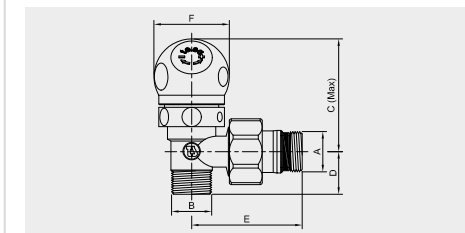

Art.	A	B	C	D	E	F
114TDR/1-03	3/8"	1/2"	65	20	49	Ø39
114TDR/1-04	1/2"	1/2"	65	23	56	Ø39
114TDR/1-045	1/2"	3/4"	65	24	61	Ø39
114CDR/1-03	3/8"	1/2"	43	20	49	Ø36
114CDR/1-04	1/2"	1/2"	43	23	56	Ø36
114CDR/1-045	1/2"	3/4"	43	24	61	Ø36



115CDR/1

ART.
115TDR/1

IT Valvola termostattizzabile dritta a doppia regolazione per tubo rame, plastica o multistrato, con manopola, senza raccordo, con autotenuta sul bocchettone. Disponibile con cappuccio di protezione (Art. 115CDR/1).

EN Double adjustment thermostatic straight valve for copper, plastic or multilayer pipe, with handle, without fitting, with self-sealing on the tailpiece. Available with protection cap (Art. 115CDR/1).

FR Robinet thermostatisable droit double réglage pour tubes cuivre, plastique ou multicouche, avec poignée, sans raccord, avec auto-étanchéité sur le raccord. Disponible avec capuchon de chantier (Art. 115CDR/1).

RU Прямой термостатический клапан с двойной регулировкой для медной, пластиковой или многослойной трубы, с регулировочной ручкой, без фитинга, с уплотнительным кольцом. Возможна поставка с защитным колпачком (Art.115CDR/1).

Art.	Size	QTY	PKT
115TDR/1-03	3/8"	10	50
115TDR/1-04	1/2"	10	50
115TDR/1-045	1/2"x3/4"E	10	50
115CDR/1-03	3/8"	10	50
115CDR/1-04	1/2"	10	50
115CDR/1-045	1/2"x3/4"E	10	50

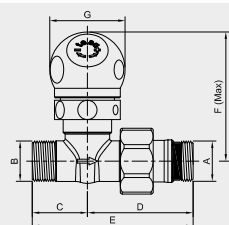

Art.	A	B	C	D	E	F	G
115TDR/1-03	3/8"	1/2"	30	50	80	68	Ø39
115TDR/1-04	1/2"	1/2"	30	53	83	68	Ø39
115TDR/1-045	1/2"	3/4"	29	58	87	68	Ø39
115CDR/1-03	3/8"	1/2"	30	50	80	46	Ø36
115CDR/1-04	1/2"	1/2"	30	53	83	46	Ø36
115CDR/1-045	1/2"	3/4"	29	58	87	46	Ø36



ART.
114S

IT Valvola termostattizzabile a doppia squadra per tubo rame, plastica o multistrato, senza raccordo. Nella versione destra e sinistra. Con autotenuta sul bocchettone.

EN Double angled chrome plated thermostatic valve for copper, plastic or multilayer pipes, without fitting. Right-hand and left-hand version. With self-sealing on the tailpiece.

FR Robinet thermostatisable double équerre, pour tube cuivre, plastique et multicouche. Sans raccord. Dans la version droite et gauche. Avec auto-étanchéité sur le raccord.

RU Двойной угловой хромированный термостатический клапан для медной, пластиковой или многослойной трубы, без фитинга. С возможностью установки справа или слева. С уплотнительным кольцом.

Art.	Size	QTY	PKT
114S-045-DX	1/2"x3/4"E	10	50
114S-045-SX	1/2"x3/4"E	10	50

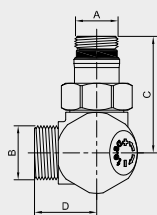

Art.	A	B	C	D
114S-045-DX	1/2"	3/4"	56	30
114S-045-SX	1/2"	3/4"	56	30



ART.
105S

IT Detentore a doppia squadra per tubo rame, plastica o multistrato, senza raccordo. Reversibile per installazione destra o sinistra. Con autotenuta sul bocchettone.

EN Double angled chrome plated lockshield valve for copper, plastic or multilayer pipes, without fitting. Reversible for right or left installation. With self-sealing on the tailpiece.

FR Té de réglage chromé pour tubes cuivre, plastique ou multicouche. Sans raccord. Réversible pour l'installation droite ou gauche. Avec auto-étanchéité sur le raccord.

RU Двойной угловой хромированный запорный вентиль для медной, пластиковой или многослойной трубы, без фитинга. С возможностью установки справа или слева. С уплотнительным кольцом.

Art.	Size	QTY	PKT
105S-045	1/2"x3/4"E	10	50

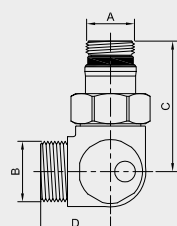

Art.	A	B	C	D
105S-045	1/2"	3/4"	56	30



ART.
136/1

IT Valvola termostattizzabile a squadra mono-bitubo per tubo rame, plastica o multistrato, senza raccordi, con autotenuta sul bocchettone. Interasse 50 mm.

EN Single-double pipe thermostatic angle valve for copper, plastic or multilayer pipe, without fittings, with self-sealing on the tailpiece. Centre distance 50 mm.

FR Robinet thermostatisable mono-bitube, équerre, adaptateur pour tube cuivre, plastique ou multicouche sans raccord, entraxe 50 mm.

RU Термостатический угловой клапан для однотрубной - двухтрубной системы, с фитингом для медной, пластиковой или многослойной трубы, с уплотнительным кольцом. Межосевое расстояние 50 мм.

Art.	Size	QTY	PKT
136/1-045-DX	1/2"x3/4"E	1	5
136/1-045-SX	1/2"x3/4"E	1	5

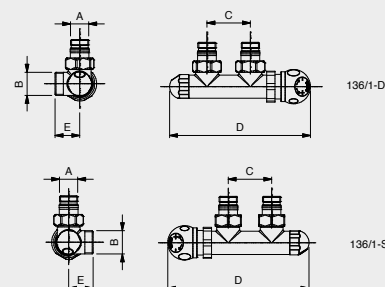

Art.	A	B	C	D	E
136/1-045-DX	1/2"	3/4"	50	163	29
136/1-045-SX	1/2"	3/4"	50	163	29



ART.
116-01

IT Testa termostatica con sensore incorporato a liquido.

EN Thermostatic head with built-in liquid sensor.

FR Tête thermostatique avec bulbe à soufflet intégré.

RU Термостатическая головка со встроенным жидкостным датчиком.

Art.	Size	QTY	PKT
116-01	M30x1,5	1	50

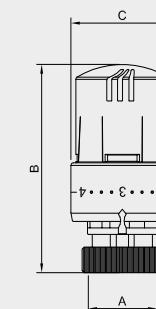

Art.	A	B	C
116-01	Ø30x1,5	84	Ø42



ART.
207

IT Raccordo a compressione 1/2" per tubo rame con tenuta O-Ring.

EN Compression fitting 1/2" for copper pipe with O-Ring seal.

FR Raccord à visser 1/2" pour tube cuivre avec O-Ring.

RU Обжимной фитинг 1/2» для медной трубы с уплотнительным кольцом O-Ring.

Art.	Size	QTY	W
207-04-10	1/2"-10	50	250
207-04-12	1/2"-12	50	250
207-04-14	1/2"-14	50	250

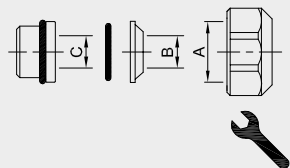

Art.	A	B	C	W
207-04-10	1/2"	Ø10,2	Ø10,2	24
207-04-12	1/2"	Ø12,2	Ø12,2	24
207-04-14	1/2"	Ø14,2	Ø14,2	24



ART.
208

IT Raccordo a compressione monoblocco 1/2" o 3/4" Eurocono per tubo rame.

EN Pre-assembled compression fitting 1/2" or 3/4" Eurocone for copper pipe.

FR Raccord à visser monobloc 1/2" ou 3/4" Eurocone pour tube cuivre.

RU Обжимной фитинг, предварительно собранный, 1/2» или 3/4» евроконус, для медной трубы.

Art.	Size	QTY	W
208-04-10	1/2"-10	50	250
208-04-12	1/2"-12	50	250
208-04-14	1/2"-14	50	250
208-04-15	1/2"-15	50	250
208-04-16	1/2"-16	50	250
208-05-12	3/4"-12	50	250
208-05-14	3/4"-14	50	250
208-05-15	3/4"-15	50	250
208-05-16	3/4"-16	50	250
208-05-18	3/4"-18	50	250

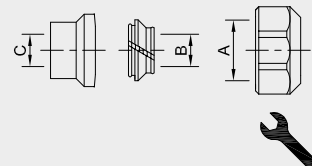

Art.	A	B	C	W
208-04-10	1/2"	Ø10,2	Ø10	24
208-04-12	1/2"	Ø12,2	Ø12	24
208-04-14	1/2"	Ø14,2	Ø14	24
208-04-15	1/2"	Ø15,2	Ø15	24
208-04-16	1/2"	Ø16,2	Ø16	24
208-05-12	3/4"	Ø12,2	Ø12	30
208-05-14	3/4"	Ø14,2	Ø14	30
208-05-15	3/4"	Ø15,2	Ø15	30
208-05-16	3/4"	Ø16,2	Ø16	30
208-05-18	3/4"	Ø18,2	Ø18	30



ART.
206

IT Raccordo a compressione per tubo polietilene da 1/2".

EN Compression fitting 1/2" for polyethylene pipe.

FR Raccord à compression pour tube polyéthylène 1/2".

RU Обжимной фитинг 1/2» для полиэтиленовой трубы.

Art.	Size	QTY	W
206-04-12020	1/2"-12x2	50	250
206-04-14020	1/2"-14x2	50	250
206-04-15020	1/2"-15x2	50	250
206-04-15025	1/2"-15x2,5	50	250
206-04-16020	1/2"-16x2	50	250
206-04-16022	1/2"-16x2,25	50	250
206-04-16025	1/2"-16x2,5	50	250

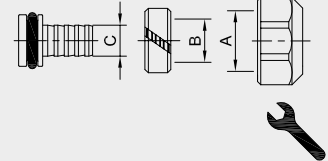

Art.	A	B	C	W
206-04-12020	1/2"	Ø12,3	Ø7,8	24
206-04-14020	1/2"	Ø14,3	Ø9,8	24
206-04-15020	1/2"	Ø15,3	Ø10,8	24
206-04-15025	1/2"	Ø15,3	Ø9,8	24
206-04-16020	1/2"	Ø16,3	Ø11,8	24
206-04-16022	1/2"	Ø16,3	Ø11,4	24
206-04-16025	1/2"	Ø16,3	Ø10,8	24



ART.
218

IT Raccordo a compressione 1/2" per tubo multistrato.

EN Raccordo a compressione 1/2" per tubo multistrato.

FR Raccord à serrer 1/2" pour tube multicouche.

RU Обжимной фитинг 1/2» для многослойной трубы.

Art.	Size	QTY	W
218-12020	1/2"-12x2	50	250
218-14020	1/2"-14x2	50	250
218-16020	1/2"-16x2	50	250
218-16022	1/2"-16x2,25	50	250
218-16530	1/2"-16x2,5	50	250

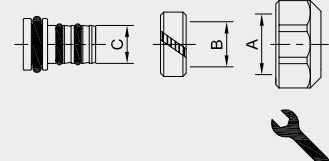

Art.	A	B	C	W
218-12020	1/2"	Ø12,3	Ø7,8	24
218-14020	1/2"	Ø14,3	Ø9,8	24
218-16020	1/2"	Ø16,3	Ø11,8	24
218-16022	1/2"	Ø16,3	Ø11,4	24
218-16530	1/2"	Ø16,8	Ø10,3	24



ART.
216T

IT Raccordo a compressione monoblocco 3/4" Eurocono per tubo polietilene.

EN Pre-assembled compression fitting 3/4" Eurocone for polyethylene pipe.

FR Raccord à serrer monobloc 3/4" Eurocone pour tube polyéthylène.

RU Обжимной фитинг, предварительно собранный, 3/4» евроконус, для полиэтиленовой трубы.

Art.	Size	QTY	W
216T-14020	3/4"-14x2	50	250
216T-15015	3/4"-15x1,5	50	250
216T-16015	3/4"-16x1,5	50	250
216T-16020	3/4"-16x2	50	250
216T-16022	3/4"-16x2,25	50	250
216T-17020	3/4"-17x2	50	250
216T-18020	3/4"-18x2	50	250
216T-18025	3/4"-18x2,5	50	250
216T-20020	3/4"-20x2	50	250
216T-20025	3/4"-20x2,5	50	250

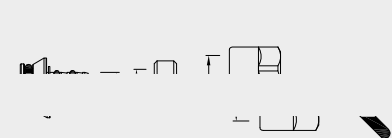

Art.	A	B	C	W
216T-14020	3/4"	Ø14,3	Ø9,8	27
216T-15015	3/4"	Ø16,3	Ø11,8	27
216T-16015	3/4"	Ø16,3	Ø11,4	27
216T-16020	3/4"	Ø17,3	Ø12,8	27
216T-17020	3/4"	Ø18,3	Ø13,8	27
216T-18020	3/4"	Ø20,3	Ø15,8	27
216T-18025	3/4"	Ø20,3	Ø14,8	27



ART.
217T

IT Raccordo a compressione monoblocco 3/4" Eurocono per tubo multistrato.

EN Pre-assembled compression fitting 3/4" Eurocone for multilayer pipe.

FR Raccord à serrer monobloc 3/4" Eurocone pour tube multicouche.

RU Обжимной фитинг, предварительно собранный, 3/4» евроконус, для многослойной трубы.

Art.	Size	QTY	W
217T-14020	3/4"-14x2	50	250
217T-16020	3/4"-16x2	50	250
217T-16022	3/4"-16x2,25	50	250
217T-17020	3/4"-17x2	50	250
217T-18020	3/4"-18x2	50	250
217T-20020	3/4"-20x2	50	250
217T-20025	3/4"-20x2,5	50	250

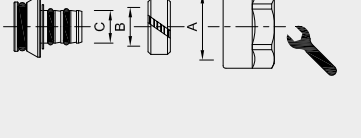

Art.	A	B	C	W
217T-14020	3/4"	Ø14,3	Ø9,8	27
217T-16020	3/4"	Ø16,3	Ø11,8	27
217T-16022	3/4"	Ø16,3	Ø11,4	27
217T-17020	3/4"	Ø17,3	Ø12,8	27
217T-18020	3/4"	Ø18,3	Ø13,8	27
217T-20020	3/4"	Ø20,3	Ø15,8	27
217T-20025	3/4"	Ø20,3	Ø14,8	27

**CONDIZIONI GENERALI DI VENDITA**

Le vendite sono da noi effettuate unicamente alle “condizioni” qui di seguito riportate così che ogni ordine da noi accettato viene evaso alle suddette condizioni, che il Committente accetta incondizionatamente.

1. Gli ordini o gli impegni assunti dai nostri rappresentanti sono validi unicamente dietro nostra accettazione o conferma scritta.
2. I dati, le misure, gli articoli, i prezzi, le caratteristiche, le prestazioni e tutti gli altri dati riprodotti nei nostri cataloghi, hanno carattere puramente indicativo e possono essere variati senza alcun preavviso.
3. I prezzi si intendono quelli concordati o in vigore al momento della consegna. Rimane nostro esclusivo diritto l'eventuale variazione del listino.
4. Le nostre merci viaggiano a rischio e pericolo del destinatario, in quanto vendute “Franco nostro stabilimento”, salvo diversa indicazione scritta. Pertanto esse non sono mai assicurate da noi per il trasporto, salvo dietro espressa richiesta del cliente, che se ne addossa il relativo onere.
5. In caso di avaria, poiché i nostri imballaggi sono eseguiti a regola d'arte, occorrerà formulare le riserve d'uso e le richieste di risarcimento esclusivamente nei confronti dei trasportatori.
6. I termini di consegna sono solo indicativi. L'acquirente ci esonera, pertanto, da ogni e qualsiasi ritardo nella consegna delle merci.
7. Reclami riguardanti la qualità e la quantità della merce dovranno essere fatti per iscritto entro otto giorni dal ricevimento. Tali reclami motivati, ci potranno obbligare alla sostituzione od integrazione pura e semplice dell'articolo difettoso o mancante, senza diritto di rifusione di danni di qualsiasi specie.
8. Tutti i pagamenti devono essere effettuati presso la nostra sede. I medesimi vengono riconosciuti come avvenuti, solo dopo il ricevimento presso di noi, anche se trasmessi da nostri agenti. In caso di pagamento dilazionato, la mancata osservanza di un termine di scadenza, comporta la decadenza automatica dal termine, la esigibilità immediata dell'intero ammontare, e la decorrenza degli interessi di mora e della rivalutazione monetaria secondo gli indici Istat del costo della vita della Camera di Commercio di Novara.
9. Per qualsiasi controversia derivante dalla nostra vendita, il contratto sarà disciplinato dalla Legge Italiana e la competenza sarà unicamente del Foro di Novara.

I prodotti contenuti in questo catalogo listino sono progettati e costruiti nell'ambito di un sistema di gestione per la qualità conforme alla norma UNI EN ISO 9001.

GENERAL SALES CONDITIONS

Sales are carried out only under the following “conditions” so that each order we accept is satisfied under such conditions.

1. Orders or commitments taken by our representatives are valid only after our acceptance or confirmation.
2. Data, measurements, items, prices, features, performances and any other data reported on our catalogues, are indicative; they can vary without prior notice.
3. Prices are those agreed upon at the moment of delivery. Any variation of price catalogues is our exclusive right.
4. Our goods travel at the risk of the addressee, given that they are considered as sold in plant, unless differently indicated in written form. So they are never insured by us for shipment, unless the customer expressly requires it, he will thus be charged with the expenses.
5. In case of fault, given that our packaging is optimally manufactured it will be necessary to draft utilization disclaimers and indemnification claims against the carriers.
6. Delivery terms are only indicative. The purchaser exempts us from any liability for damages due to a delay in goods delivery.
7. Claims concerning quality and quantity of the goods shall be submitted within an eight days term after the receipt. These claims, justified by plausible reasons, can oblige us to replace or just totally integrate the faulty or missing item, without the right of indemnification.
8. All payments have to be made at our premises. In case of deferred payment, failure to comply with an expiry term, entails the automatic lapse of the term, the immediate chargeability of the entire sum, and the running of delay interests and monetary re-assessment in compliance with Istat cost-of-life indexes of the Novara Chamber of Commerce.
9. For any litigation arising from our sale, the contract shall be regulated by the Italian Law and competence shall be exclusively of the Novara Court.

The products contained in this catalogue are designed and manufactured in the ambit of a Quality Management System according to UNI EN ISO 9001 norm.

CONDITIONS GENERALES DE VENTE

Nos ventes sont effectuées uniquement selon les « conditions » indiquées ci-dessous. Toute commande acceptée est livrée effectivement à ces conditions:

1. Les commandes ou les engagements pris par nos agents ne sont valables que par suite à notre accord ou confirmation.
2. Les données, les dimensions, les articles, les prix, les caractéristiques, les prestations et toutes les autres informations présentes dans nos catalogues, sont à considérer à titre indicatif ; ils peuvent être modifiés sans préavis.
3. Les prix indiqués sont ceux concordés ou en vigueur au moment de la livraison. La société se réserve le droit à modifier le tarif.
4. Nos marchandises voyagent aux risques et périls du destinataire, dans la mesure où elles sont vendues franco notre usine, sauf indication contraire écrite. Nous n'assurons jamais le transport, sauf si demandé par le client, qui en paiera les frais.
5. Vu que nos produits sont bien emballés, en cas de dommage, les demandes d'indemnisation et réserves d'usage doivent être rédigées exclusivement aux transporteurs.
6. Le délai de livraison est toujours donné à titre indicatif et, dans aucun cas de retard de livraison ou d'expédition, l'acheteur peut refuser la totalité ou une partie des marchandises.
7. Le client devra communiquer les plaintes éventuelles concernant la qualité et la quantité des produits dans un délai de huit jours à partir de leur réception. Notre garantie se limite au remplacement ou à l'intégration de l'article défectueux ou manquant, et ne couvre en aucun cas l'indemnisations de toutes sortes.
8. Tous les paiements doivent nous être effectués directement et sont considérés reçus seulement après leur réception. En cas de paiement différé, le non-respect d'une échéance nous autorise à suspendre les délais de paiement prévus, et à exiger le paiement complet, les intérêts de retard et la mise en demeure préalable selon l'indice ISTAT du cout de la vie de la Chambre de Commerce de Novara.
9. Pour tout litige résultant de nos ventes, la compétence exclusive appartient au tribunal de Novara.

Les produits dans ce tarif ont été projetés et produits selon un système de gestion pour la qualité en conformité de la norme UNI EN ISO 9001.

ОБЩИЕ УСЛОВИЯ ПРОДАЖ

Продажи осуществляются только при условиях перечисленных ниже, каждый принятый нами заказ запускается в производство при условиях, которые клиент принимает безоговорочно.

1. Заказы или обязательства принятые нашими представителями действительны исключительно после письменного подтверждения.
2. Цены, артикулы, размеры и дополнительные характеристики указанные в нашем каталоге могут быть ориентировочными и могут быть изменены без предварительного уведомления.
3. Согласованные цены действительны в момент доставки, покупатель не имеет право вносить какие-либо изменения в прайс-листе без нашего согласия.
4. Мы не несем ответственность за товар с момента его отгрузки с фабрики, могут быть исключения которые указываются заранее в письменной форме.
5. В случае повреждения и нарушения упаковки товара, нужно предъявить жалобу по страховому случаю транспортной компании.
6. Сроки поставки могут быть ориентировочными, покупатель не несет ответственности в случае возможной задержки.
7. Возможные жалобы по сервису и качеству принимаются исключительно в письменной форме в течении 8 дней с момента получения товара. Исключительно в случае производственного дефекта или неполадки по нашей вине, товар может быть заменен на новый, в противном случае покупатель не имеет права на возмещение.
8. Все платежи производятся в нашем офисе, в случае несоблюдения сроков оплаты, приводит к автоматической дисквалификации, после чего принимаются необходимые меры иска всей суммы долга и переоценки валюты в соответствии с показателем Торгово-Промышленной Палаты города Новара.
9. При разногласиях, возникающих по коммерческим причинам, договор будет нести за собой юридическую ответственность и урегулироваться по итальянскому законодательству.

Продукты содержащиеся в нашем каталоге, созданы и произведены по нормам UNI EN ISO9001 контроля и качества.

te-sa S.r.l. 2020 Tutti i diritti riservati

I contenuti di questa documentazione, in particolare testi, disegni e foto, sono di proprietà della **te-sa S.r.l.**. La riproduzione anche se parziale del contenuto è vietata salvo espressa preliminare autorizzazione scritta da parte della Direzione. Il presente catalogo annulla e sostituisce i precedenti. L'Azienda non è vincolata in nessun modo nel caso di variazioni tecniche, commerciali ed errori di stampa.

te-sa S.r.l. 2020 All rights reserved

All the information reported in this catalogue, particularly texts, drawings and pictures, are property of **te-sa S.r.l.**. A reproduction, also partial of its contents is forbidden, except for previously written authorization from the Management. This catalogue supersedes and replaces all previous edition. The Company is not bound in any way in case of technical and commercial modifications and also for printing errors.

Graphic Design and Coordination
Vecchi & Besso s.r.l.
www.vecchi-besso.it

Press
Vecchi srl - officine grafiche
Borgomanero (No) - Italy

